



NIRVANA ENGINEERING (Stafford)LTD.

*Specialist Suppliers to the Standby Power, Telecomms. U P S
and Switchgear Industries Worldwide.*

Registered Office and Works:
Dewick's Depot, Cannock Road, Brocton, Stafford ST17 0SU.
Tel: (01785) 660700 Fax: (01785) 661299

OFFSHORE STAND ASSEMBLY INSTRUCTIONS

CONTENTS

1. DELIVERY OF STAND

2. PREPARATION OF STAND PARTS

3. ASSEMBLY OF STAND

4. PLACEMENT OF BATTERY BLOCKS

1. DELIVERY OF STAND

- 1.1 *On receipt of consignment, remove package containing the fasteners and assembly instructions.*
- 1.2 *Check that all goods have been delivered undamaged, and inform the Sales Department at Nirvana should any part be missing or damaged.*

2. PREPARATION OF STAND PARTS

- 2.1 *Separate all stand parts into their respective identities, i.e. frames, cell supporting runners, retention / seismic rails, tie bars, neoprene and fasteners.*
- 2.2 *If frames are 'handed', i.e. left or right hand end frames on a terraced stand, isolate each respective frame according to it's relative position in the stands' final location.*
- 2.3 *Ensure all threaded fixing points have been cleared of all coating, before the start of assembly.*
- 2.4 *Review the stand drawing to ensure acceptable 'visualisation' of the final stand assembly form.*
- 2.5 *Ensure all female inserts are positioned in the floor prior to stand assembly.*

3. ASSEMBLY OF STAND

- 3.1 *Position each frame at the approximate relative frame spacing ('centres'), with the base plates facing in the correct direction (if appropriate).*
- 3.2 *For each tier, loosely fix each cell supporting runner in position with the appropriate fixing arrangement (see detail 'A'). Do not tighten any fixing.*
- 3.3 *Place a length of the stated size of self adhesive backed neoprene, along the full length of the internal facing sides of each cell retention rail (see detail 'C'). Note: Inner retention rails will have neoprene on both faces.*
- 3.4 *Place a length of the stated size of self adhesive backed neoprene, along the internal face of each end frame retaining end brace (see detail 'C').*
- 3.5 *For each tier and row, loosely fix each cell retention rail in position with the appropriate fixing arrangement (see fixing detail 'C'). Do not tighten any fixing.*
- 3.6 *Loosely fix each tie bar in position with the appropriate fixing arrangement (see fixing detail 'B'). Do not tighten any fixing.*
- 3.7 *Ensure all parts are 'squared-off', i.e. 90 degrees relative to each other, then torque tighten each joint to the value stated below:-*
 - M6 - 10 Nm*
 - M8 - 23 Nm*
- 3.8 *Using the stand as a template, mark off and drill the fixing holes to the floor in accordance with the anchor suppliers instructions. Note : floor fixing bolts not supplied by Nirvana.*
- 3.9 *Fix the stand to the base substrate.*
- 3.10 *Use a spirit level to ensure the stand is sited correctly, and shim the base plates if necessary.*

PLACEMENT OF BATTERY BLOCKS

- 4.1 *Whilst retaining all other frame members in place, remove all frontmost cell retention rails (per tier). The rearmost retention rail should be positioned approximately 10mm from the rear frame vertical and locked in position.*
- 4.2 *Position the rubber, or 'h', capping strip (where supplied) on each runner, as highlighted on the main drawing. (See also detail 'A')*
- 4.3 *Starting with the rear row and in accordance with the manufacturers guidelines, introduce each block / cell to each row.*
- 4.4 *On completing the accommodation of the row, re-position the front retention rail, and torque tighten each fixing.*
- 4.5 *Continue procedures 4.4 and 4.5 for each outstanding row.*
- 4.6 *In the event that the tie bars obscure, or interfere with, a row of batteries, remove each individual bar, as necessary, and replace at the earliest possible time.*

- 4.7 *For any incomplete row of battery blocks / cells, position the loose 'cross brace' (see fixing detail 'D'). This acts as a 'remote' frame end brace and the block / cell accommodation should take place with the cross brace already bolted in place.*
- 4.8 *Inter block / cell cabling should take place in line with the battery block / cell manufacturer's conditions, specifications and guidelines, as well as current Health and Safety procedures.*

If there is any aspect of the above list of instructions that appears unclear, or, does not cover an on-site problem, please do not hesitate to contact the above office, and we will endeavour to assist wherever possible.

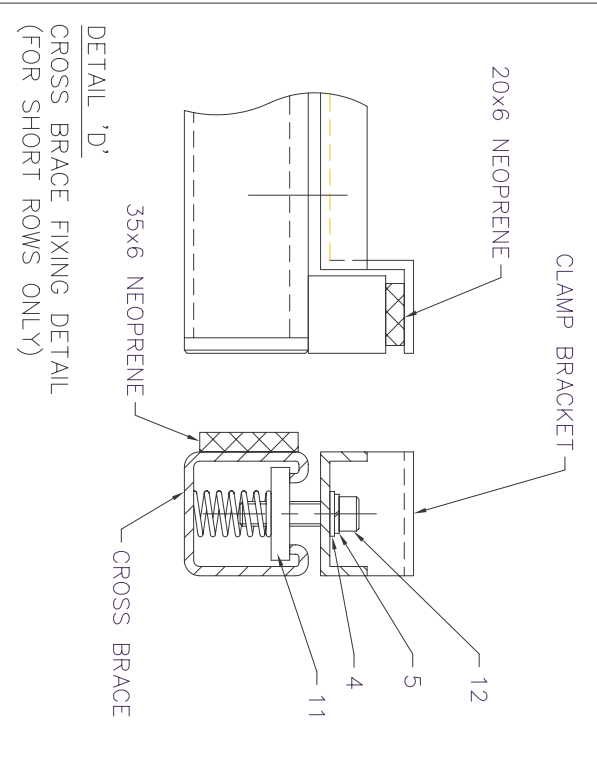
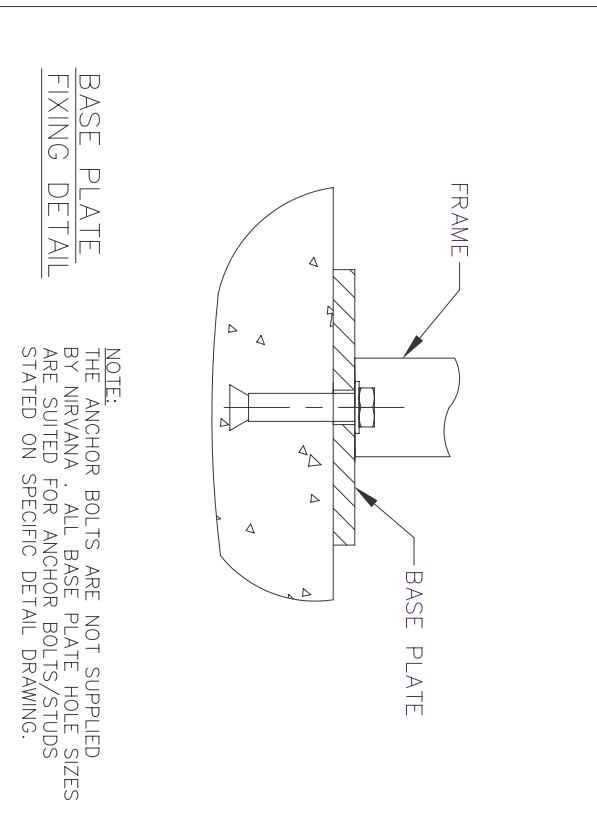
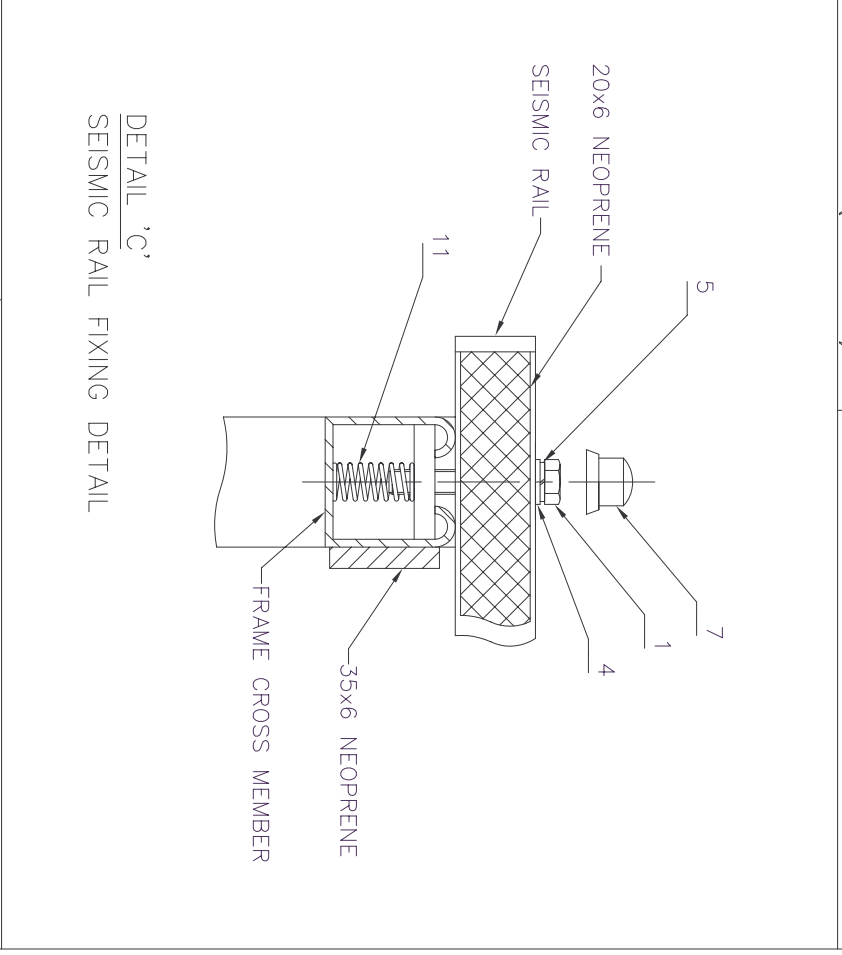
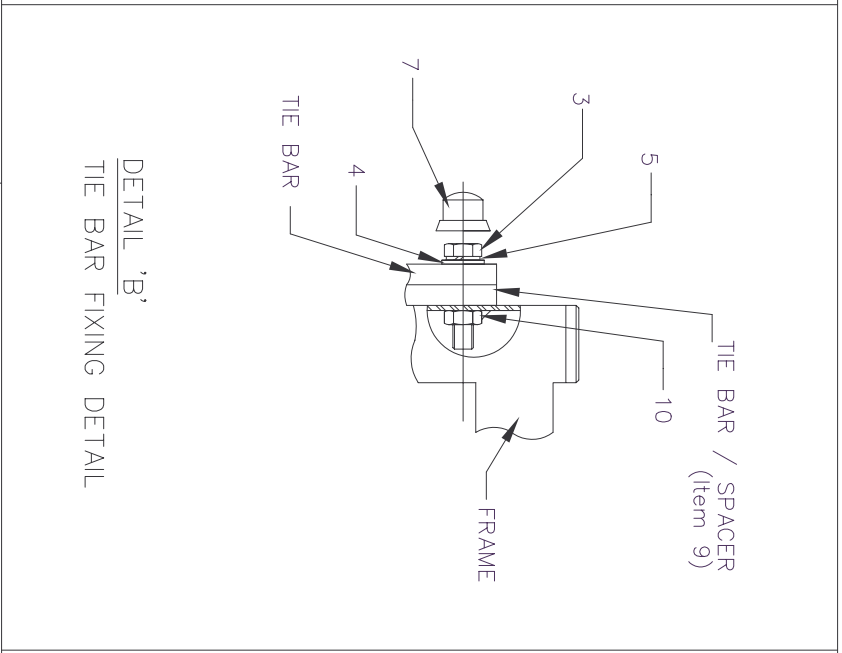
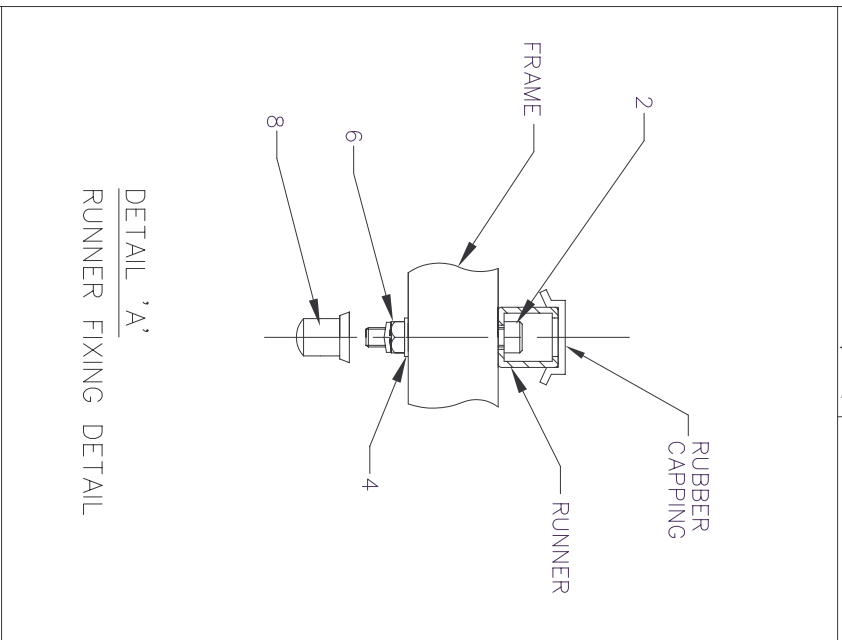

FASTENERS INDEX:

Item 1	-	M8 x 50 LG HEX HEAD BOLT (BZP)
Item 2	-	M8 x 60 LG CAPSCREW (BZP)
Item 3	-	M8 x 35 LG HEX HEAD SCREW (BZP)
Item 4	-	M8 PLAIN WASHER (BZP)
Item 5	-	M8 SPRING WASHER (BZP)
Item 6	-	M8 TORQUE RETAINING NUT (BZP)
Item 7	-	M8 PLASTIC SHORT CAP
Item 8	-	M8 PLASTIC LONG CAP
Item 9	-	8mm THICK TIE BAR SPACER (BZP)
Item 10	-	M8 NUT WELDED INSIDE TUBE
Item 11	-	M8 SPRING NUT
Item 12	-	M8 x 30 LG CAPSCREW (BZP)